

AP-840EN

Two-Way Acoustic Box



EN54-24

- ✓ Commercial PA system wall mount speaker with transformer.
- ✓ Ideal for school, offices, hotel, airports, etc.
- ✓ Compliant with the EN54-24 standards.
- ✓ Impact-resistant & UV-resistant ABS plastic housing.
- ✓ IP55 rated against adverse weather conditions.
- ✓ Integrated thermal fuse, 95°C fire-resistant cable and fire resistant dome.
- ✓ Power outputs 40W / 20W / 10W / 5W + 8 Ohms with power selector.
- ✓ Quick installation by supplied stainless mounting bracket.



Technical specifications

| | |
|--------------------|---------------------------------------|
| Model | AP-840EN |
| Description | Two-way acoustic box |
| Power output | 40W / 20W / 10W / 5W + 8Ω |
| Line input | 100V / 70V |
| Frequency response | 100-20KHz |
| SPL(@1W/m) | 90dB |
| Speakers | 6.5" woofer & 1.5" tweeter |
| Dimensions | 310×213×195mm |
| Material | ABS plastic housing with metal grill. |
| Installation | "U" stainless mounting bracket. |
| Weight | 3.7kg |

Technical reference: WSK-640HEN

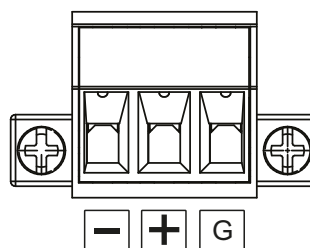
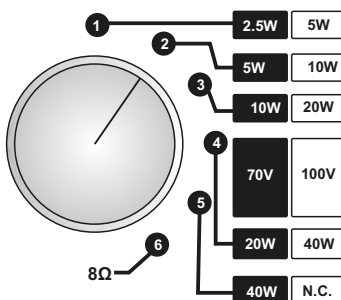
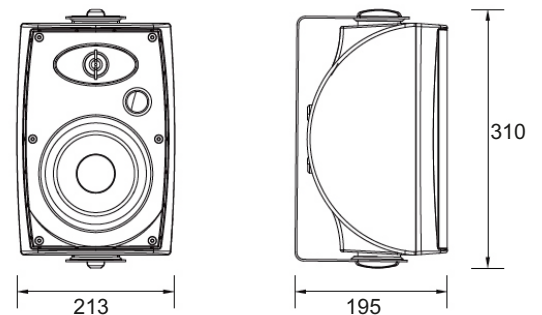

Warning: If the loudspeaker is connected to L100V, do not set the switch to position 5 and 6 under any circumstances. It will cause damage to the loudspeaker and the power amplifier to which it is connected.

The Ground connection is only necessary in certain circumstances if RF problems exist.



EQUIPOS Y SISTEMAS MEGAFONÍA/ INTERCOM • PUBLIC ADDRESS SYSTEMS

UNIÓN DESARROLLOS ELECTRÓNICOS

Tel.: +34 934 772 854 / +34 609 914 787 • ude@udeaudio.com • BARCELONA - SPAIN

www.udeaudio.com

rev.2 | 610.560A | 1 / 1

Caja acústica de 2 vías

- ✓ Caja acústica con transformador para sistema de avisos.
- ✓ Ideal para escuelas, oficinas, hoteles, aeropuertos, etc.
- ✓ Cumple con la Norma EN54-24.
- ✓ Carcasa de plástico ABS resistente a impactos y rayos UV.
- ✓ Protección IP55 contra inclemencias meteorológicas.
- ✓ Fusible térmico integrado, cable y cono resistente al fuego.
- ✓ Potencias de salida de 40W / 20W / 10W / 5W / + 8 Ohms con selector rotativo.
- ✓ Instalación rápida mediante escuadra de fijación de acero inox.



Características técnicas

| | |
|-------------------------|------------------------------------|
| Modelo | AP-840EN |
| Descripción | Altavoz 2-vías |
| Potencias | 40W / 20W / 10W / 5W + 8Ω |
| Entrada línea | 100V / 70V |
| Respuesta de frecuencia | 100-20KHz |
| SPL(@1W/m) | 90dB |
| Altavoces | 6.5" woofer & 1.5" tweeter |
| Dimensiones | 310×213×195mm |
| Material | Plastico ABS y rejilla metálica |
| Instalación | Soporte en "U" de acero inoxidable |
| Peso | 3.7kg |

Referencia técnica: WSK-640HEN

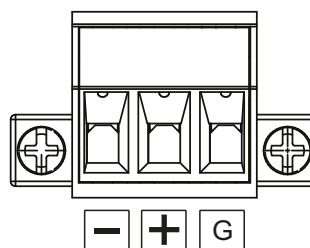
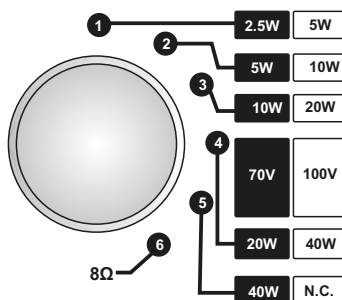
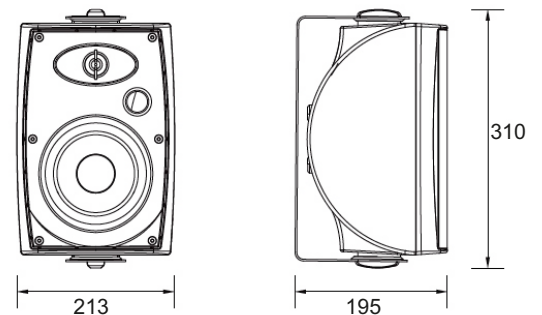

Nota importante: Si el altavoz está conectado en L100V, no situar el conmutador en ningún caso en la posición 5 y 6. Causará daños en el altavoz y la etapa de potencia a la que está conectado.

La conexión G solo es necesaria en determinadas circunstancias si existen problemas de RF.